

PLUS ATELIER

Tailored tiles



GRES PORCELLANATO
PORCELAIN STONEWARE

PLUS ATELIER

Tailored tiles

Immagina un progetto in cui pensare al gres porcellanato come a una tela da ricamo. Il nostro laboratorio Plus Atelier nasce lì, nel punto di equilibrio tra ingegneria e arte, tra esperienza e sperimentazione. Apre strade alla creatività su misura. Aggiunge strati incantevoli a rivestimenti di grandi dimensioni.

Imagine a project that allows you to view porcelain tile as a canvas on which to embroider. And so the Plus Atelier workshop is born, the perfect balance of engineering and art, experience and experimentation. The fascinating layers of material and colour that are added to the large size ceramic cladding open up new paths into tailor-made creativity.

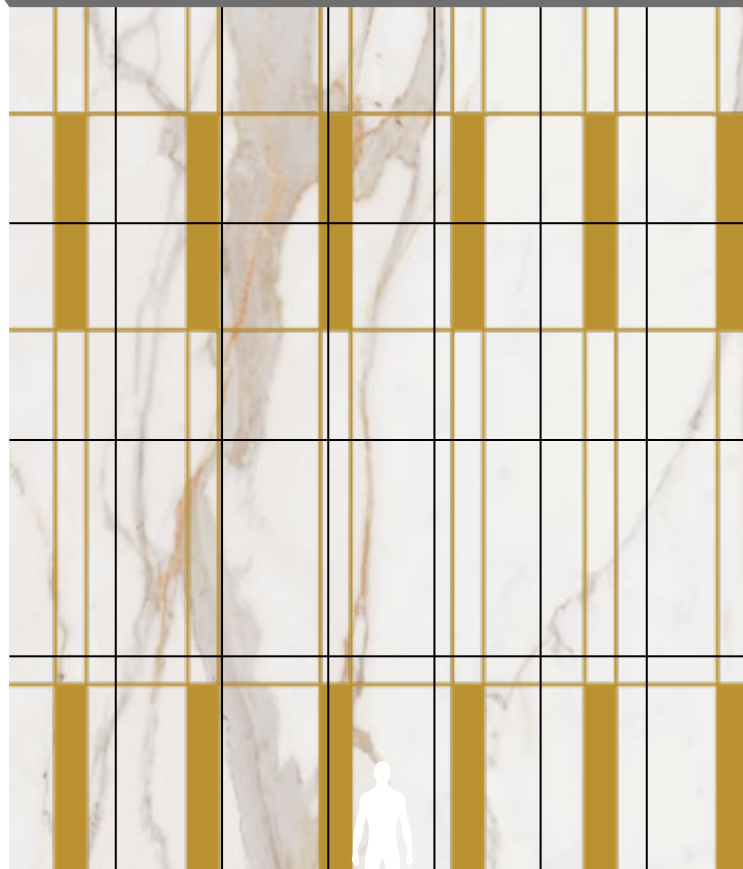

4 LAVORAZIONI/ PROCESSING

L'avanguardia della decorazione ceramica

Plus Atelier trasforma il gres porcellanato di grande formato in una tela bianca, per una libertà espressiva totale. Quattro soluzioni stilistiche per soddisfare ogni esigenza estetica e progettuale del professionista dell'architettura e del design. La materia ceramica stessa si fa progetto e si apre alla forza del colore, alla versatilità del decoro, all'unicità del rivestimento custom-made. Da oggi l'interior design personalizzato non ha più limiti.

The creative avant-garde of ceramic decoration

Plus Atelier transforms large size porcelain tile into a blank canvas, for total freedom of expression. Four style solutions to satisfy architects' and designers' every need, whether aesthetic or design-related. The ceramic material itself becomes the project, opening itself up to the power of colour, the versatility of decoration, the uniqueness of custom-made wall tiles. As of now, personalised interior design has no limits.



MATERICA

Decori preziosi

Liscia o strutturata, la lastra viene impreziosita da applicazioni che emulano la sapiente manualità di un decoratore. Spatole, pennelli o spugne di polveri metalliche, come l'oro e il platino, arricchiscono di intense suggestioni materiche e cromatiche la superficie ceramica, rendendola unica.

Precious decorations

Smooth or textured, the slab is enhanced with applications that emulate the skilled craftsmanship of a decorator. The application of metallic powders or other precious materials such as gold and platinum, adds intense material and colour suggestion to the ceramic surface, for a unique result.



DIGITALE

Decorazione in alta definizione

La lastra neutra – di qualunque superficie – acquista personalità grazie alla riproduzione a stampa di disegni o di immagini fotografiche: applicazioni grafiche ad altissima definizione possibili grazie alla migliore tecnologia digitale disponibile sul mercato, per colori vividi e naturali.

High-definition decoration

The neutral slab - of any surface - gains personality thanks to the printed reproduction of designs or photographic images: extremely high-definition graphic applications made possible thanks to the best digital technology available on the market, for vivid and natural colours.



DECORAZIONE A RILIEVO

Una grande varietà di effetti

La decorazione prende nuovo valore grazie alla possibilità di ottenere finiture e rilievi differenti, sia essa a campo pieno o materica.

A wide variety of effects

The possibility to achieve different finishes and raised surfaces adds value to the decoration, whether full body or material.



TINTA UNITA

Tutta la forza del colore

Tinte decise e vibranti o nuance neutre, uniformi o in un digradare di eleganti sfumature: una tecnica ideale per riprodurre tutti quei colori che non è possibile ottenere in linea né con altre tecniche di decorazione. Perché la creatività esige la più ampia gamma cromatica possibile.

All the power of colour

Bold and vibrant shades or neutral tones, uniform or with the fading of elegant hues: an ideal technique with which to reproduce all those colours that cannot be achieved on the line or using other decorative techniques. Because creativity requires the widest possible colour palette.

project process

Plus Atelier è un'originale espressione di tecnologia in cui le eccellenti performance del gres porcellanato incontrano nuove tecniche di decorazione, in equilibrio tra innovazione e gusto ricercato. Soluzioni stilistiche ideali tanto per l'interior design quanto per applicazioni esterne e per facciate decorate; ma anche un affidabile materiale d'arredo per piani di lavoro, pareti divisorie, porte scorrevoli e ogni altra applicazione di design.

Plus Atelier is an original expression of technology in which the outstanding qualities of porcelain tile meet with decorative techniques, for a balance between technological innovation and refined taste. Style solutions that are as suited to interior design as they are to external application and decorative façades; but also a reliable furnishing material for use as work tops, dividing walls, sliding doors and any other design application.



1. CONCEPT IDEA

Metodo e ispirazione

Ogni buona idea ha un'anima duplice: è fatta di metodo e di ispirazione, di un rigoroso lavoro di sintesi in grado di dare solide fondamenta a un innesco spesso casuale fatto di suggestioni distanti tra loro. Poi tocca alla mano: spetta a lei trovare la via più promettente. Schizzo dopo schizzo, l'idea si costruisce attorno un corpo insieme al quale evolvere.

Method and inspiration

Every good idea has a dual soul and comprises method, inspiration and precise work by which to give solid foundations to an often random trigger, the two sharing distant suggestions. Then it's down to the hand: it's up to you to find the most promising path. Sketch after sketch, the idea is built around a body with which to evolve.

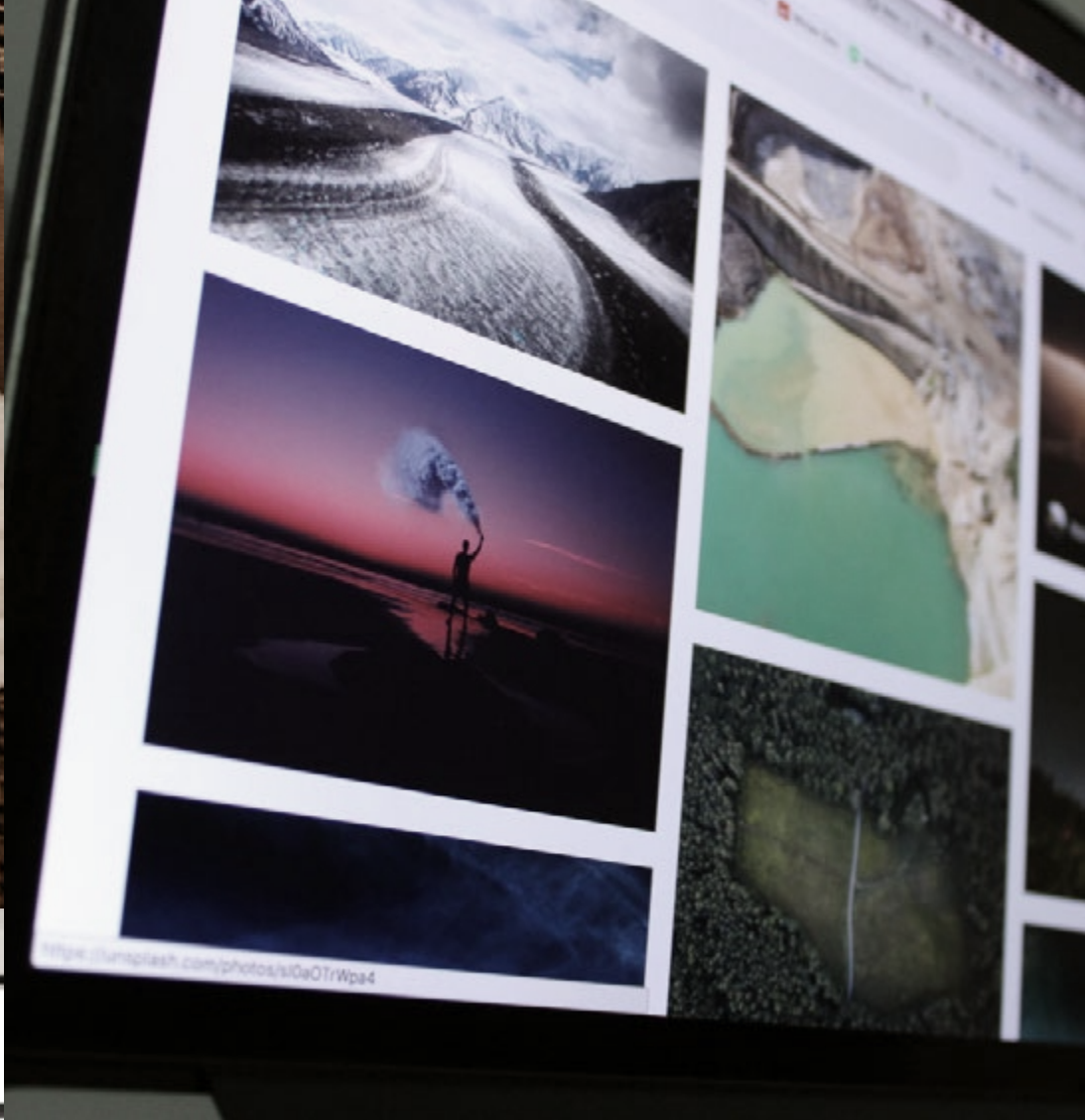

2. PROJECT

Dall'idea alla forma

Fin da subito il progetto nasce come un sistema estetico-funzionale in grado di tenere tutto insieme: una complessità crescente e organizzata che arriva a definire spazi e proporzioni, interno ed esterno, verticalità e orizzontalità. E all'interno della quale forme, colori e materiali trovano espressività e coerenza stilistica.

From idea to form

Right from the start, the project was designed as an aesthetic/functional system able to bring everything together and growing in organised complexity as it defines spaces and proportions, interiors and exteriors, verticality and horizontality, and within which the shapes, colours and materials find stylistic expressiveness and coherence.



3. PRODUCT CHOOSING



Strumenti di design

La varietà di look e di effetti estetici ottenibili fanno del progetto Plus Atelier uno strumento di design fondamentale. Colori unici, originali motivi grafici, inserti materici preziosi e alterazioni della riflessione superficiale: le grandi lastre ceramiche custom-made contribuiscono in modo determinante a dare al progetto carattere e unicità.

Design tools

The variety of looks and aesthetic effects that can be achieved make the Plus Atelier project a fundamental design tool. Unique colours, original graphic motifs, precious material inserts and alterations in surface reflection: the large custom-made ceramic slabs contribute in a significant way to giving the project character and uniqueness.

a new project is born

Inedito ed esclusivo, Plus Hotel è un progetto realizzato grazie alla versatilità e all'efficienza di Plus Atelier. Dall'involucro architettonico alla progettazione degli spazi interni, dagli arredi ai dettagli dell'interior design, Plus Hotel è un ecosistema stilistico senza eguali.

Il percorso creativo che, partendo dal concept iniziale, ha originato le palette colori e le texture grafiche e materiche si è concretizzato in un progetto di design ceramico solido e coerente.

Brand-new and exclusive, Plus Hotel is a project executed thanks to the versatility and effectiveness of Plus Atelier. From the architectonic shell to the design of interior spaces, from the furnishings to interior design details, Plus Hotel is an ecosystem of unrivalled style. Starting from the initial concept, the creative pathway that shapes the colour palette and graphic and material textures becomes an extremely solid and coherent ceramic design project.

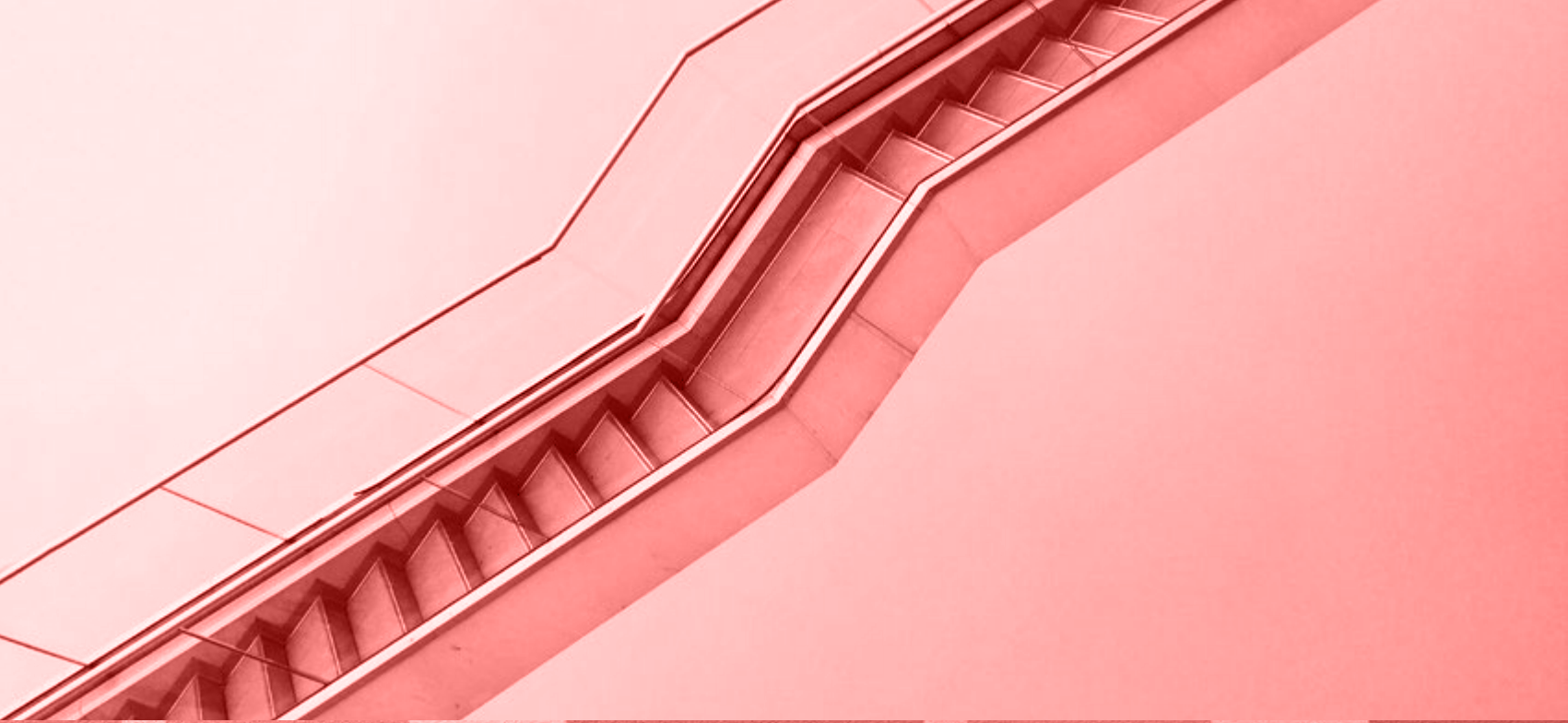
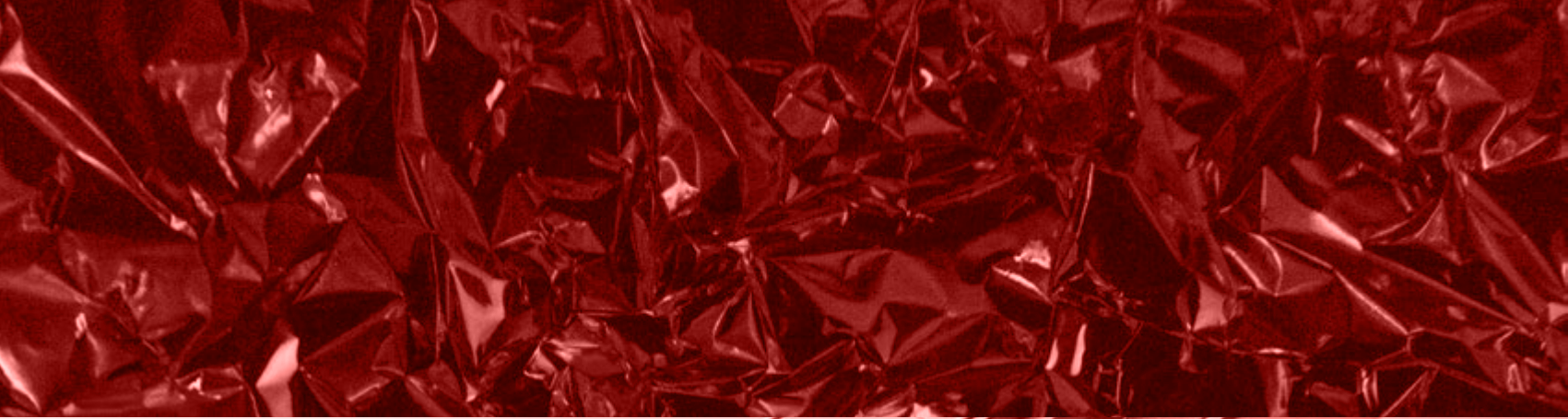

outdoor

PAVIMENTO / FLOOR
DESIGN GREY
60x120 (24"x48") K2 20 MM

RIVESTIMENTO / WALL
DECORO TINTA UNITA
120x278 (48"x110")



OUTDOOR



PAVIMENTO/ FLOOR

DESIGN GREY



● 60x120 (48"x110 ") RT 9 mm

RIVESTIMENTO/ WALL

DESIGN GREY



● 120x278 (48"x110 ") RT 6 mm



120x278 (48"x110 ") RT 6 mm
DESIGN GREY CON DECORO TINTA UNITA
COLORE 1675U



120x278 (48"x110 ") RT 6 mm
DESIGN GREY CON DECORO TINTA UNITA
COLORE 181U



120x278 (48"x110 ") RT 6 mm
DESIGN GREY CON DECORO TINTA UNITA
COLORE 173U

SPECIFICHE TECNICHE/ TECNICAL FEATURES

GRES PORCELLANATO TUTTA MASSA UGL
FULL-BODY PORCELAIN UGL

SPESSORI
THICKNESSES

6 mm (120x278)
20 mm (60x120)

DECORO REALIZZATO CON LA TECNICA TINTA UNITA
DECORATION WITH SOLID COLOR TECHNIQUE

COLORI UTILIZZATI
CHOSEN COLORS
1675U - 181U - 173U

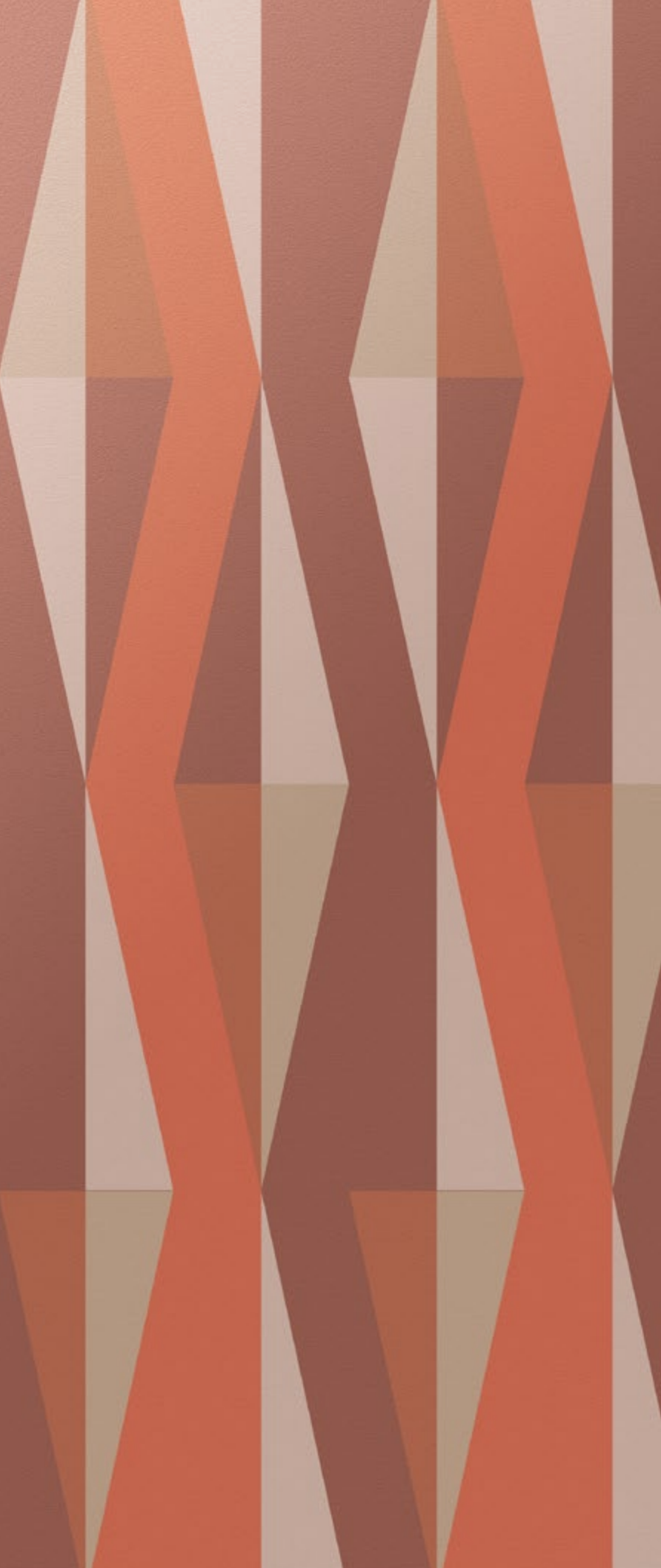

reception



PAVIMENTO / FLOOR
DESIGN GREY
120x120 (48"x48")

RIVESTIMENTO / WALL
DECORO DIGITALE
60x120 (24"x48")

RECEPTION



PAVIMENTO/ FLOOR

DESIGN GREY



● 60x120 (48"x110") RT 9 mm

RIVESTIMENTO/ WALL

DESIGN GREY



● 120x278 (48"x110") RT 6 mm



120x278 (48"x110") RT 6 mm
DESIGN GREY



120x278 (48"x110") RT 6 mm
DESIGN GREY CON DECORO DIGITALE A CAMPO PIENO

SPECIFICHE TECNICHE/ TECNICAL FEATURES

GRES PORCELLANATO TUTTA MASSA UGL
FULL-BODY PORCELAIN UGL

SPESSORI
THICKNESSES

6 mm (120x278)
9 mm (60x120)

DECORO REALIZZATO CON LA TECNICA DIGITALE
DECORATION WITH DIGITAL TECHNIQUE

COLORI UTILIZZATI
CHOSEN COLORS

NERO - 167U - 173U - 181U - 7403U - 7536U - 401U - 1675

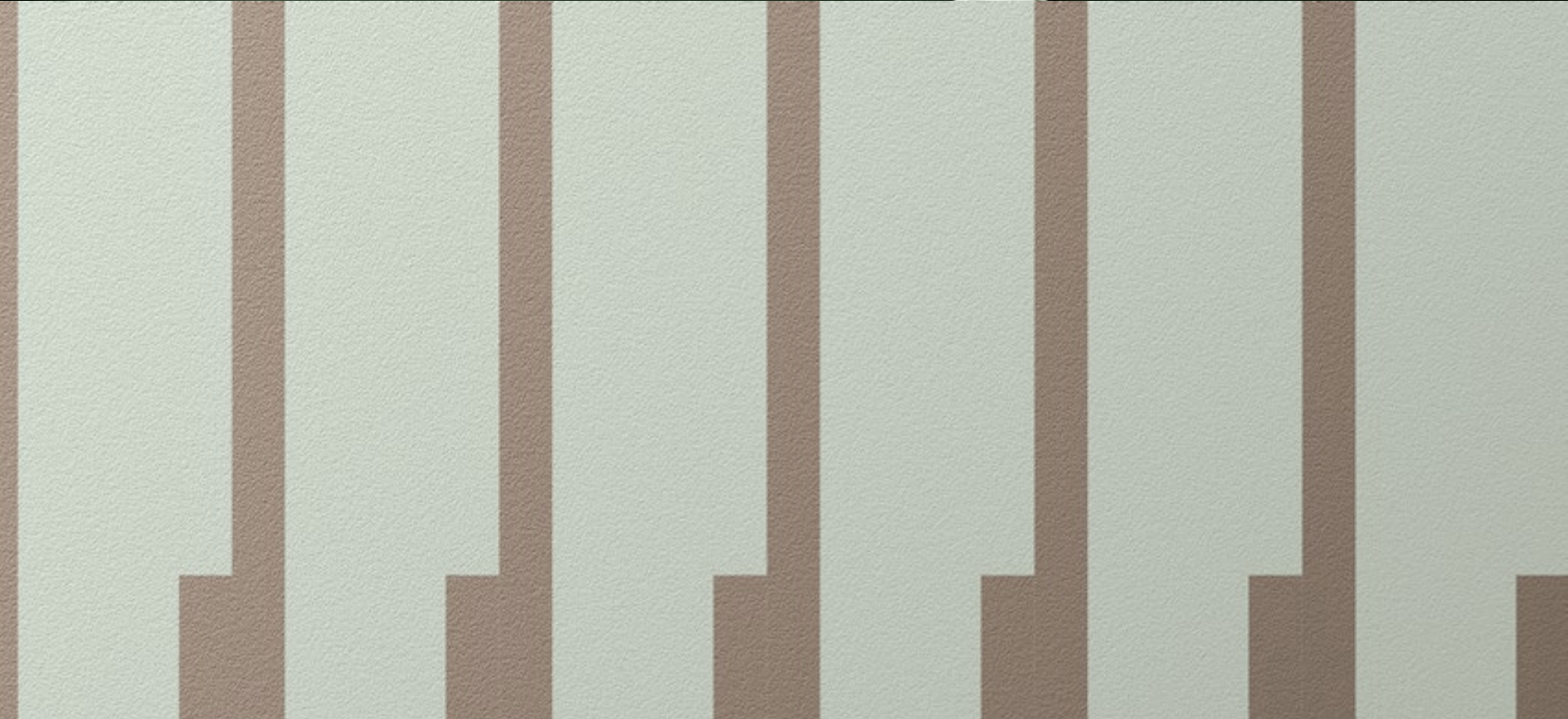

living

PAVIMENTO / FLOOR
DESIGN GREY
120X120 (48"x48")

RIVESTIMENTO / WALL
ECLETIC MISTIQ WHITE
120X278 (48"x110")

DECORO A RILIEVO
120x278 (48"x110")



LIVING



PAVIMENTO/ FLOOR

DESIGN GREY



● 120x120 (48"x110 ") RT 9 mm

RIVESTIMENTO/ WALL

MISTIQ WHITE



● 120x278 (48"x110 ") RT 6 mm

IKON SILVER



● 120x278 (48"x110 ") RT 6 mm



120x278 (48"x110") RT 6 mm
IKON SILVER

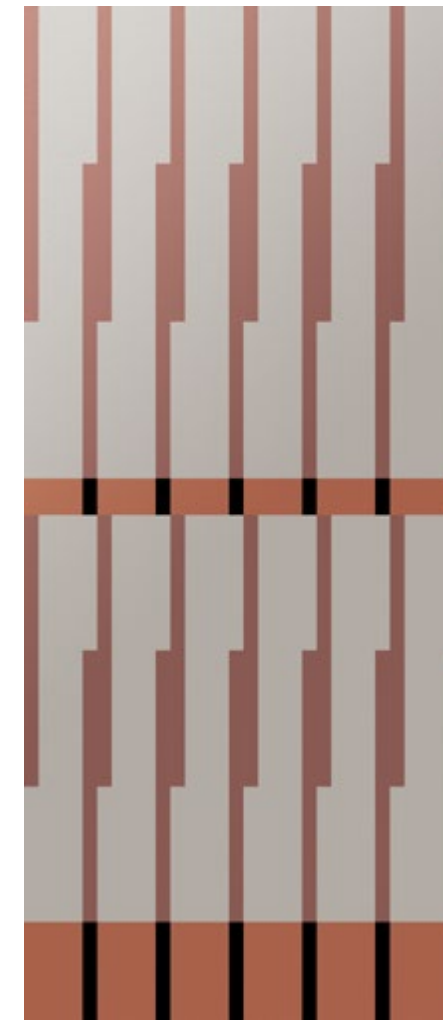

120x278 (48"x110") RT 6 mm
IKON SILVER CON DECORO A RILIEVO



SPECIFICHE TECNICHE/ TECNICAL FEATURES

GRES PORCELLANATO TUTTA MASSA UGL
FULL-BODY PORCELAIN UGL

SPESSORI
THICKNESSES

6 mm (120x278)
9 mm (120x120)

DECORO REALIZZATO CON DECORO A RILIEVO
DECORATION WITH IN RELIEF TECHNIQUE

COLORI UTILIZZATI
CHOSEN COLORS

401U - 181U - 173U

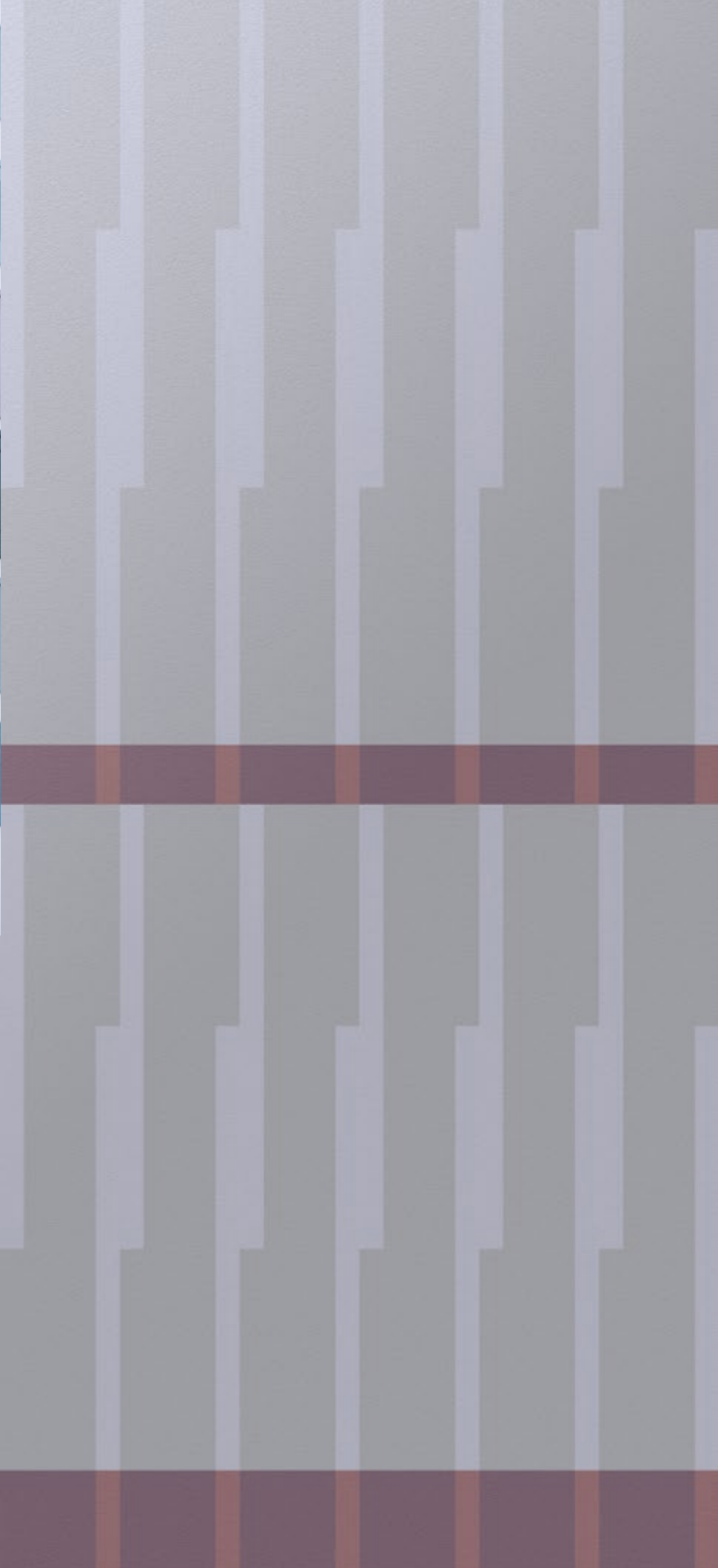

bedroom



PAVIMENTO / FLOOR
IKON SILVER
120x120 (48"x48")

RIVESTIMENTO / WALL
DECORO A RILIEVO
120x278 (48"x110")

BEDROOM



PAVIMENTO/ FLOOR

IKON SILVER



● 120x120 (48"x110") RT 9 mm

RIVESTIMENTO/ WALL

IKON SILVER



● 120x278 (48"x110") RT 6 mm



120x278 (48"x110 ") RT 6 mm
IKON SILVER

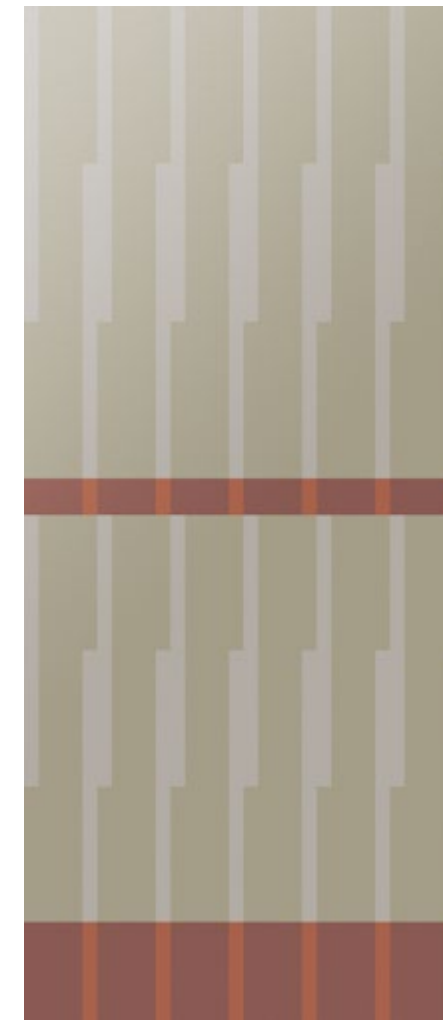

120x278 (48"x110 ") RT 6 mm
IKON SILVER CON DECORO A RILIEVO CON RISERVE

SPECIFICHE TECNICHE/ TECNICAL FEATURES

GRES PORCELLANATO TUTTA MASSA UGL
FULL-BODY PORCELAIN UGL

SPESSORI
THICKNESSES

6 mm (120x278)
9 mm (120x120)

DECORO REALIZZATO CON DECORO A RILIEVO
DECORATION WITH IN RELIEF TECHNIQUE

COLORI UTILIZZATI
CHOSEN COLORS
401U - 181U - 173U

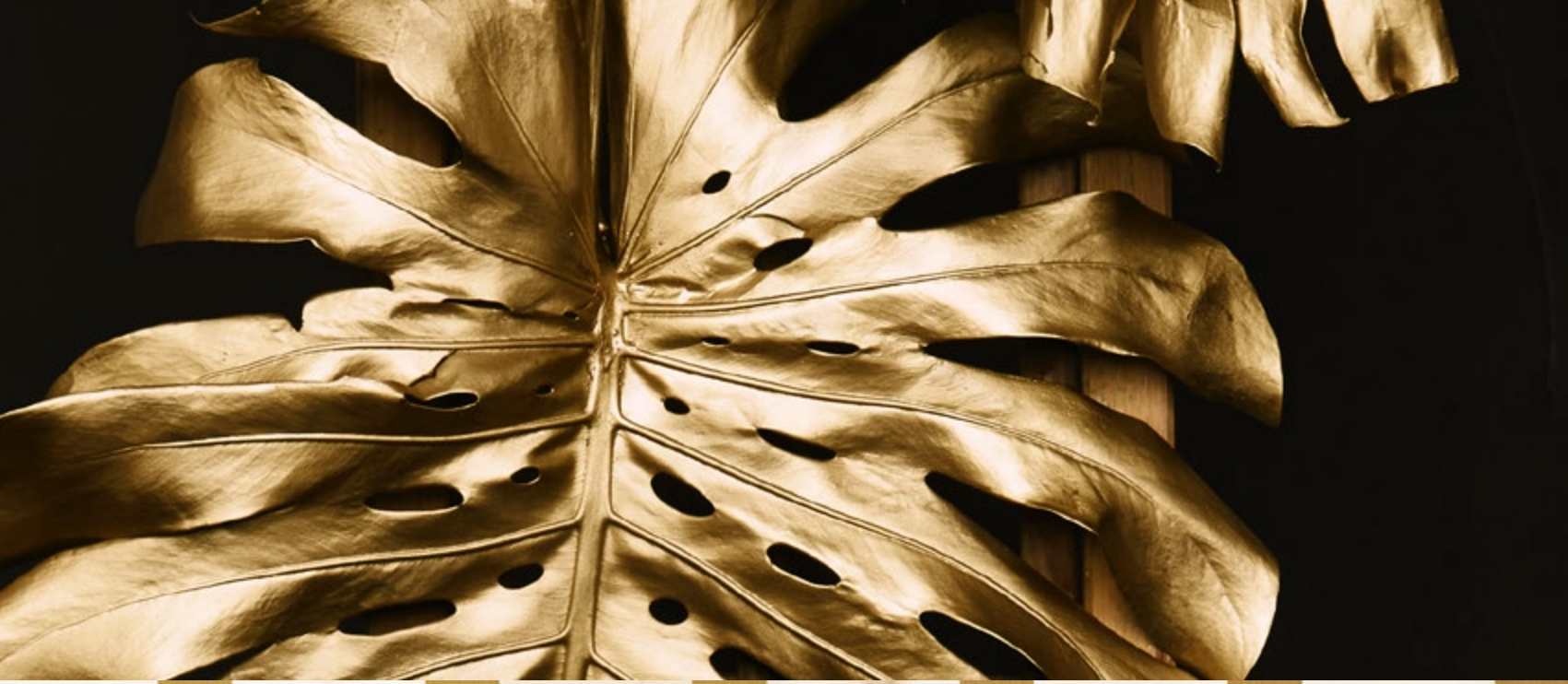

bathroom

PAVIMENTO / FLOOR
CALACATTA GOLD
120x120 (48"x110")

RIVESTIMENTO / WALL
DECORO MATERICO
120x278 (48"x110")

HOME DECOR PLUS ATELIER

LAVELLO DA APPOGGIO CON BASE
CALACATTA GOLD
50x160 (20"x64")



BATHROOM



PAVIMENTO/
FLOOR
 ELEMENTS LUX CALACATTA GOLD



◆ 120x120 (48"x110") RT 9 mm

SPECIFICHE TECNICHE/
TECNICAL FEATURES

GRES PORCELLANATO TUTTA MASSA UGL
FULL-BODY PORCELAIN UGL

SPESSORI
THICKNESSES

6 mm (120x278)
 9 mm (120x120)

DECORO REALIZZATO CON LA TECNICA MATERICA
DECORATION WITH THE MATERIAL TECHNIQUE

COLORI UTILIZZATI
CHOSEN COLORS
 OTTONE

RIVESTIMENTO/
WALL
 ELEMENTS LUX CALACATTA GOLD

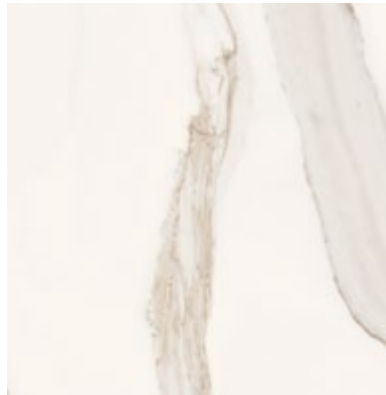

◆ 120x278 (48"x110 ") RT 6 mm



120x278 (48"x110") RT 6 mm
 CALACATTA GOLD



120x278 (48"x110") RT 6 mm
 CALACATTA GOLD CON DECORO MATERICO

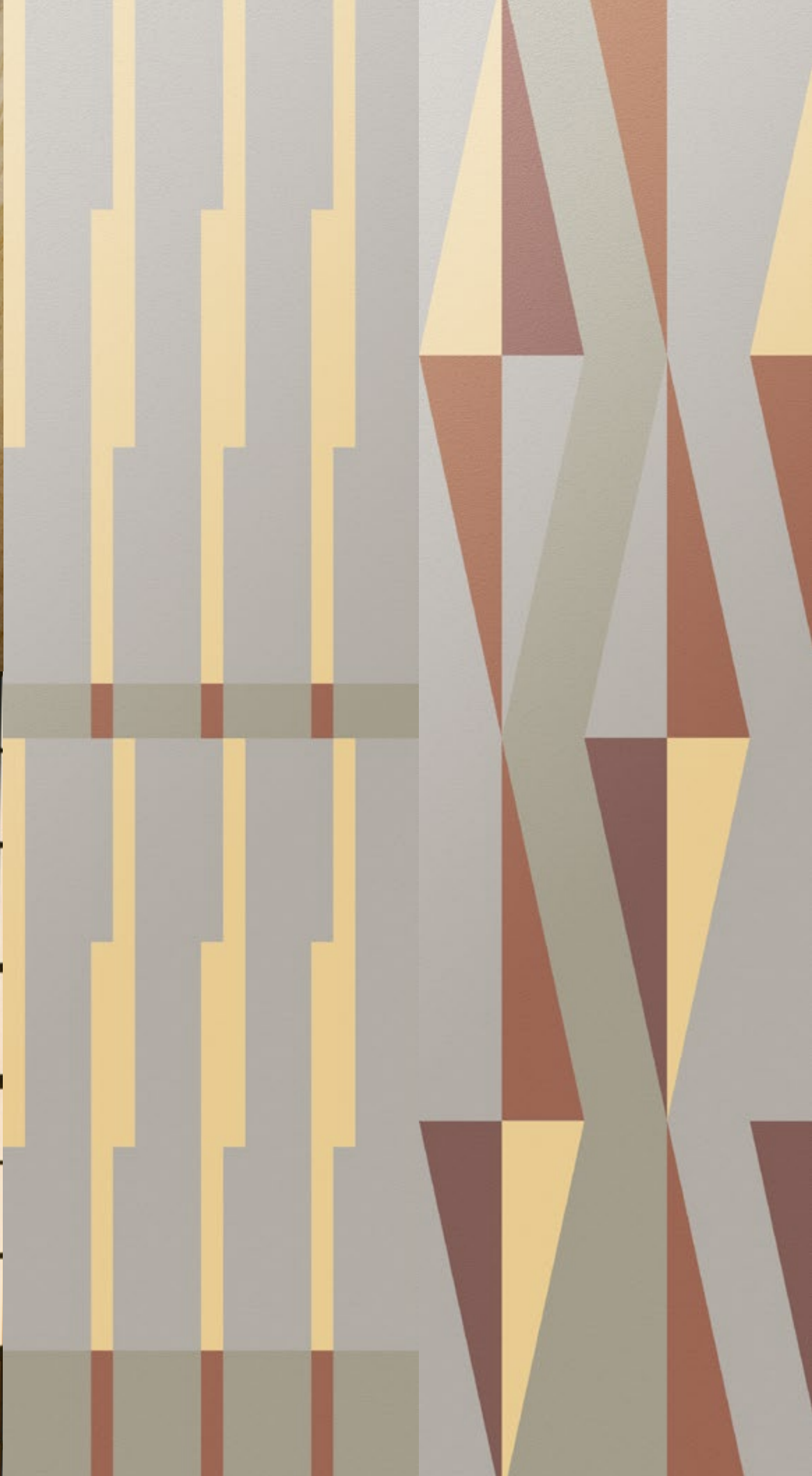
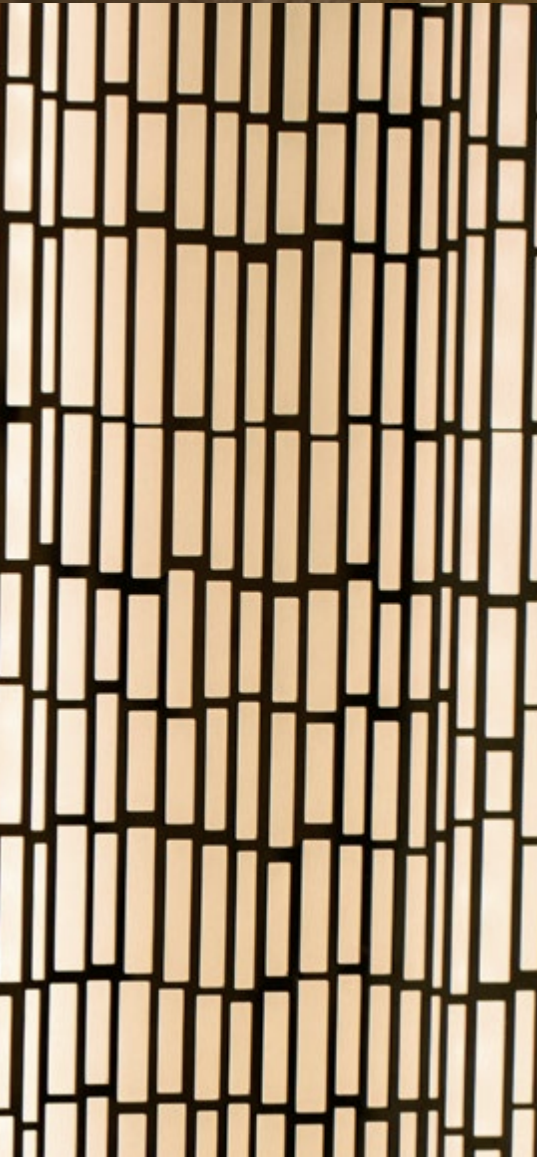

spa



PAVIMENTO / FLOOR
ARAN WALNUT
60x120 (24"x48")
RIVESTIMENTO / WALL
60x120 (24"x48")- 30x120 (12"x48")
DECORO DIGITALE / A RILIEVO
120x278 (48"x110")

SPA



PAVIMENTO/ FLOOR

ARAN WALNUT



● 60x120 (24"x48") RT 9 mm

SPECIFICHE TECNICHE/ TECHNICAL FEATURES

GRES PORCELLANATO TUTTA MASSA UGL
FULL-BODY PORCELAIN UGL

SPESSORI
THICKNESSES

6 mm (120x278)
9 mm (120x120)

DECORI REALIZZATI CON LE TECNICHE DIGITALE E
A RILIEVO
DECORATION WITH THE DIGITAL AND IN RELIEF
TECHNIQUES

COLORI UTILIZZATI
CHOSEN COLORS

NERO - 167U - 173U - 181U - 7403U - 7536U - 401U - 1675U

RIVESTIMENTO/ WALL

ELEMENTS DESIGN GREY



● 120x278 (48"x110") RT 6 mm



120x278 (48"x110") RT 6 mm
DESIGN GREY



120x278 (48"x110") RT 6 mm
DESIGN GREY CON DECORO DIGITALE

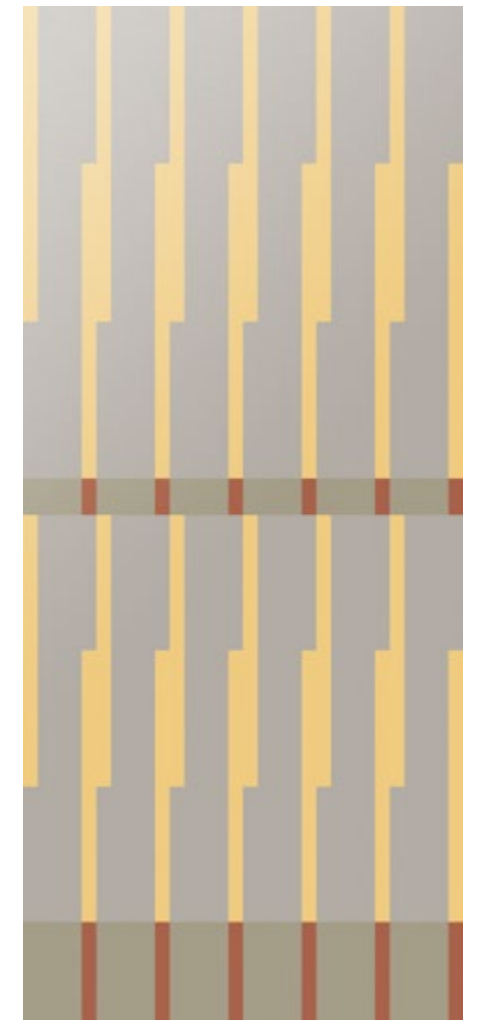

120x278 (48"x110") RT 6 mm
DESIGN GREY CON DECORO A RILIEVO

PLUS ATELIER

**RESA ESTETICA SUPERIORE CON
CONTINUITÀ CROMATICA ED ESTETICA
TRA LASTRE DECORATE E FONDO**
*SUPERIOR AESTHETIC YIELD WITH
CHROMATIC AND AESTHETIC CONTINUITY
BETWEEN DECORATED AND BASE SLABS*

VERSATILITA' D'USO
VERSATILITY OF USE

PERFORMANCE DEL GRES
FULL-BODY PORCELAIN UGL

**IDEALE PER INTERNI/ESTERNI,
RESIDENZIALI E COMMERCIALI**
*IDEAL FOR INTERIOR/EXTERIOR,
RESIDENTIAL AND COMMERCIAL*

DALL'IDEA AL PRODOTTO

FROM IDEA TO PRODUCT

Definito il progetto da realizzare sono necessarie solo quattro semplici passi

Once the project to be implemented has been defined only four simple activities will be required

- 1. CREA IL TUO PROGETTO IN FORMATO VETTORIALE E INSERISCI I RIFERIMENTI RAL**
CREATE YOUR PROJECT IN VECTOR FORMAT AND INSERT RAL REFERENCES
- 2. CONTATTA L'UFFICIO MARKETING KEOPE**
CONTACT THE KEOPE'S MARKETING OFFICE
- 3. RICEVI IL PREVENTIVO IN DUE SETTIMANE**
GET THE ESTIMATE IN TWO WEEKS
- 4. QUANDO CONFERMATO VERRÀ REALIZZATO UN CAMPIONE 30x30 PER APPROVAZIONE**
WHEN CONFIRMED A 30x30 SAMPLE WILL BE CREATED FOR APPROVAL
- 5. IN 4/6 SETTIMANE IL TUO PROGETTO SARÀ CONSEGNATO**
IN 4/6 WEEKS YOUR PROJECT WILL BE DELIVERED

SPECS&TECH

FORMATI LAVORABILI/

WORKABLE SIZES



120X278 (48"x110") RT 6 mm

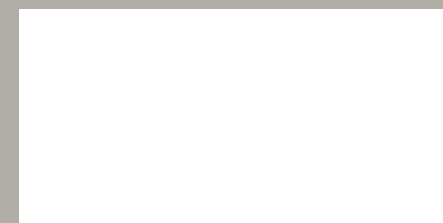

60x120 (24"x48") RT 9 mm



120X240 (48"x96") RT 9 mm

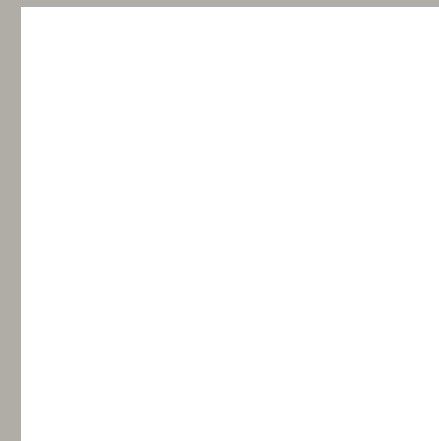

120x120 (48"x48") RT 9 mm

SPECS&TECH

SPECIFICHE TECNICHE/
TECHNICAL DATA

IT_

Resistente all'usura, alle sollecitazioni meccaniche, ai detergenti chimici, agli sbalzi termici e alle abrasioni, Plus Atelier è il nuovo, versatile partner dei professionisti del design pensato per le grandi superfici residenziali e commerciali, le grandi opere e il mondo del contract.

EN_

Resistant to wear, mechanical stress, chemical detergents, sudden temperature changes and abrasions, PLUS ATELIER is the new and versatile partner for design professionals, conceived for large residential and commercial surfaces, large-scale works and the contract world.

IT_

Tecnologia collaudata in grado di sostenere la fornitura di consistenti lotti di materiale, producendo fino a 500 MQ al giorno.

50MQ / Lotto minimo per tipologia di lavorazione e grafica (100MQ per Tinta Unita)

EN_

Proven technology able to support the supply of consistent material batches, producing up to 500 sqm per day.

50sqm / minimum lot by technique of decoration and graphics (100MQ for plain colors)



RESISTENZA ABRASIONE PROFONDA (UGL)
DEEP ABRASION RESISTANCE (UGL)



RESISTENZA A ROTTURA
BREAKING STRENGTH



RESISTENZA SHOCK TERMICI
THERMAL SHOCK RESISTANCE



RESISTENZA CHIMICA
CHEMICAL RESISTANCE

IT_

Attenzione. Le lavorazioni Materica e Decorazione a rilievo sono indicate solo a rivestimento. E' possibile ottenere decorazioni digitali con protezioni per alto calpestio o con caratteristiche antiscivolo, qualora sia richiesto.

EN_

Warning. The raised Material and Decoration products are only recommended for use as cladding. Digital decorations with protection for high-traffic areas or with non-slip characteristics can be created on request.

HOME DECOR | SPECS&TECH

SPECIFICHE TECNICHE/
TECHNICAL DATA

IT_

Gli arredi sono disponibili con il rivestimento in gres porcellanato di tutte le collezioni presenti nel Catalogo Generale per cui è disponibile il formato di partenza 120x278 - nel caso del Tavolo Rettangolare e Tavolo Plus Atelier - ed il formato 120x120 per gli altri arredi. Al momento dell'ordine sarà necessario indicare il fondo di partenza selezionato.

Per tutti gli articoli Home Decor è necessario considerare una tolleranza dimensionale di $\pm 2/3$ mm.

EN_

For the coverings of the furniture items, it's required to specify the desired surface, selecting it from the many available in the General Catalogue, for which the 120x278 size - in the case of the Rectangular Table and Plus Atelier Table - and the 120x120 size - for the other furnishings - are available. At the time of the order it will be necessary to indicate the selected starting fund.

For all Home Decor items consider a tolerance of $\pm 2/3$ mm with respect to the sizes indicated.

IT_

Gli arredi Home Decor sono realizzati con un processo di lavorazione artigianale che ne garantisce la qualità e cura del dettaglio.

Per l'assemblaggio delle varie parti degli elementi dell'arredo bagno vengono utilizzati collante C2/TE e resine poliuretaniche.

EN_

The Home Decor furnishings are made with a craftsmanship process that guarantees quality and attention to detail.

For the assembly of the various parts of the bathroom furnishing elements, C2 / TE adhesive and polyurethane resins are used.

HOME DECOR



LAVELLO A COLONNA
COLUMN SINK



DISPONIBILE IN / AVAILABLE IN
50x50x85 cm

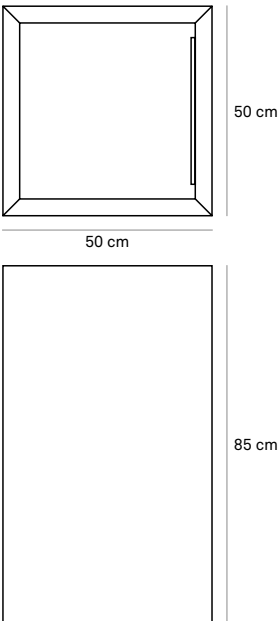

LAVELLO DA APPOGGIO
COUNTERTOP SINK



DISPONIBILE IN / AVAILABLE IN
35x50x12 cm

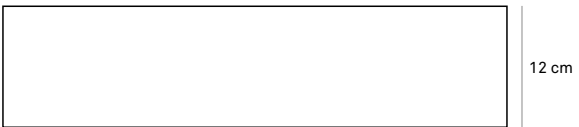
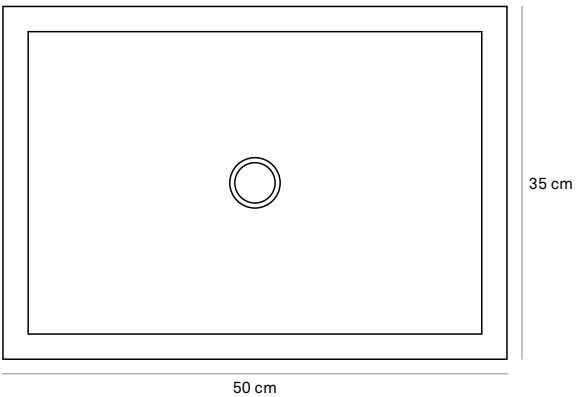

DISPONIBILE IN / AVAILABLE IN
50x120x12 cm
50x160x12 cm

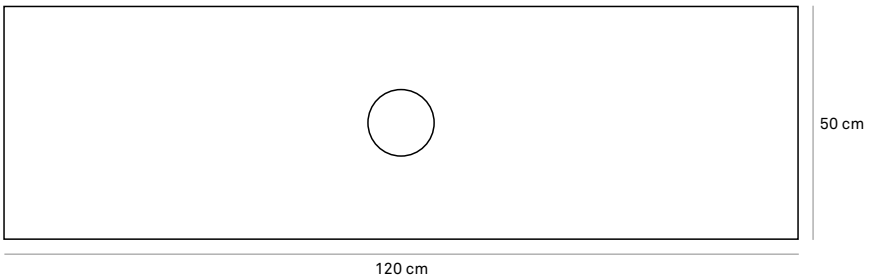

specs & tech | home decor

HOME DECOR



PIATTO DOCCIA*
SHOWER TRAY



DISPONIBILE IN / AVAILABLE IN

- 80x120 cm
- 80x135 cm
- 90x135 cm
- 90x160 cm

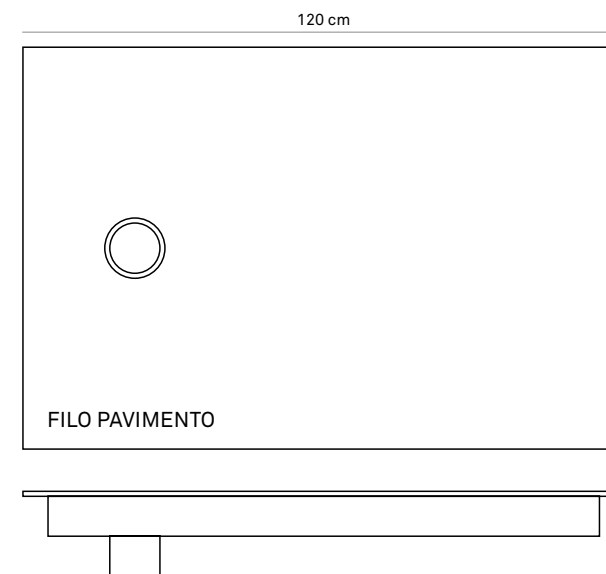

DISPONIBILE IN / AVAILABLE IN

- 80x120x4 cm
- 80x135x4 cm
- 90x135x4 cm
- 90x160x4 cm

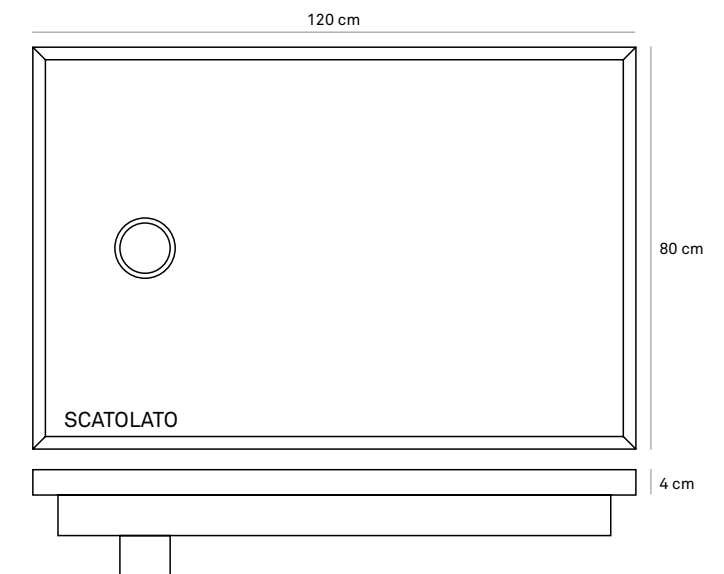

TAVOLINO CIRCOLARE
CIRCULAR TABLE



DISPONIBILE IN / AVAILABLE IN

- Ø 42 cm H 50 cm
- Ø 58 cm H 50 cm
- Ø 73 cm H 39 cm

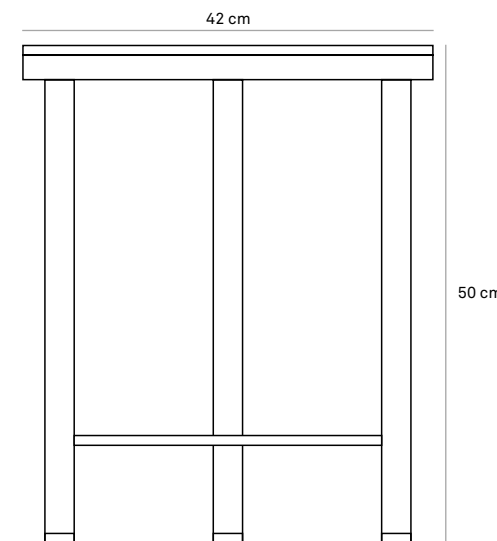

IT_

***Attenzione.** Per ottenere una superficie antiscivolo nel piatto doccia è necessario stendere un tappeto idoneo ad assicurare una presa sicura del piede in presenza di acqua.

EN_

***Warning.** To obtain a non-slip surface in the shower tray it is necessary to lay down a carpet suitable to ensure a secure grip of the foot in the presence of water.

HOME DECOR



TAVOLO RETTANGOLARE
RECTANGULAR TABLE



DISPONIBILE IN / AVAILABLE IN
95x200x75 cm



DISPONIBILE IN / AVAILABLE IN
95x175x75 cm

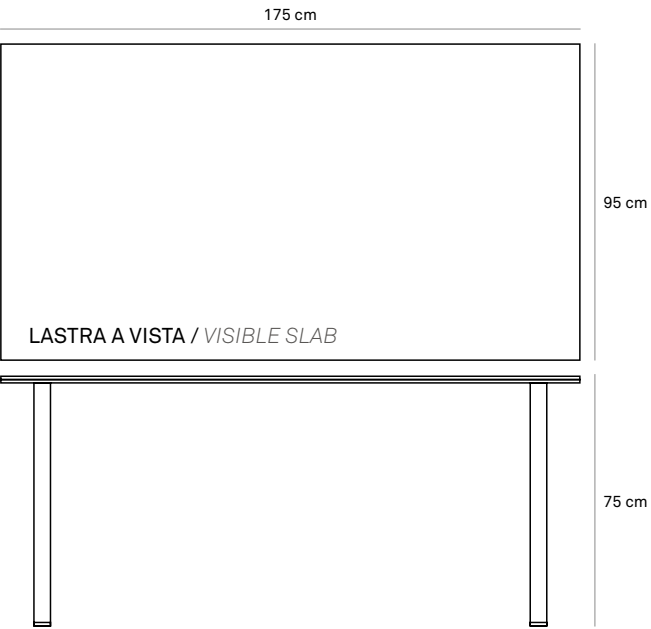

TAVOLO PLUS ATELIER
PLUS ATELIER TABLE



PERSONALIZZABILE IN DIMENSIONE E COLORE / CUSTOMIZABLE IN SIZE AND COLOR

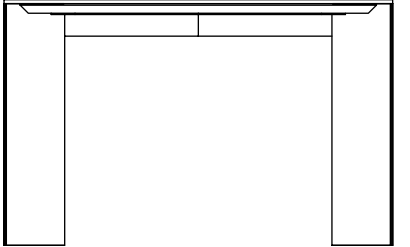
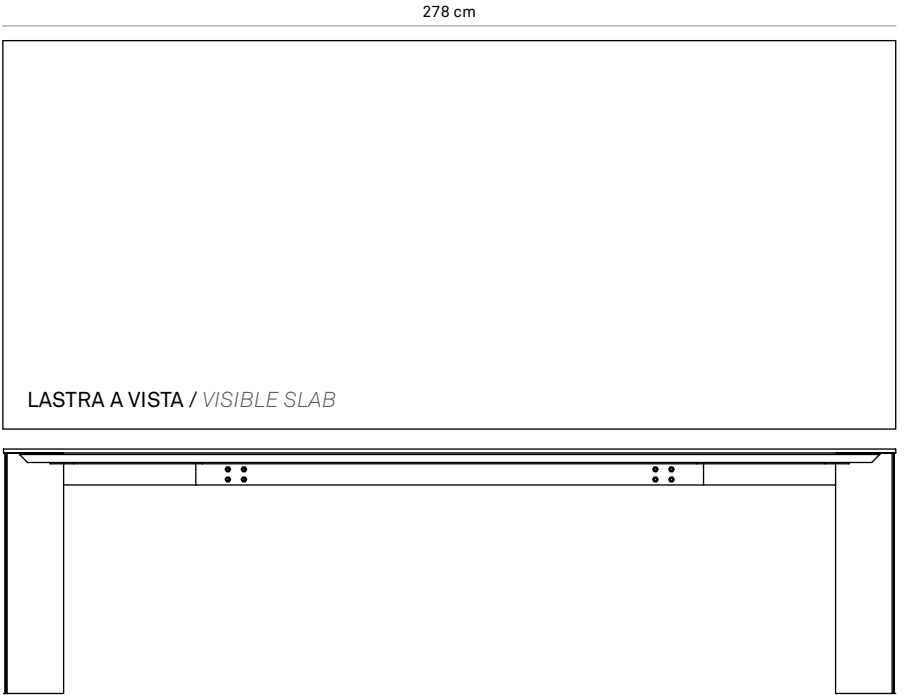

specs & tech | home decor



HEADQUARTER via statale 467, 21
42013 Casalgrande (RE) - Italy
FACTORY via canale, 67
42013 Casalgrande (RE) - Italy
WAREHOUSE via dell'industria, 1
42013 Casalgrande (RE) - Italy

PHONE +39 0522 997511
FAX +39 0522 997544 (OT) - 545 (IT)
ADMIN. FAX +39 0522 997413

info@keope.com
keope.com

IT_

Ceramiche Keope raccomanda l'utilizzo delle lastre in spessore 6 mm per le sole applicazioni in ambito residenziale, commerciale a traffico leggero e comunque in contesti ove non vi sia passaggio di carichi puntuali pesanti o transito di carrelli a ruote dure. Oltre all'utilizzo a rivestimento è inoltre possibile posarle su pavimenti preesistenti in marmo, pietra naturale o ceramica, senza la necessità di demolire la pavimentazione sottostante. Per l'applicazione su massetto Ceramiche Keope consiglia l'utilizzo del gres porcellanato in spessore tradizionale.

Ceramiche Keope si riserva la facoltà di apportare variazioni ai prodotti illustrati in questo catalogo per necessità produttive o al fine di migliorarne la qualità. I campioni sono puramente indicativi. Gli imballaggi e pesi riportati possono variare per necessità produttive. Consultare gli uffici commerciali al momento dell'ordine.

Per una posa ad opera d'arte, consultare Consigli di posa, pulizia e manutenzione al link keope.com.

EN_

Ceramiche Keope recommends the use of 6 mm thick tiles only for residential and low traffic commercial applications. These tiles are not recommended for applications involving the transit of heavy loads or hard-wheeled trolleys.

6 mm thick tiles can be installed as wall coverings and as floor coverings over existing marble, stone or ceramic floors without having to demolish the previous floor.

Ceramiche Keope recommends the use of porcelain tiles of conventional thickness for applications over screed.

Ceramiche Keope reserves the right to vary the products illustrated in this catalogue for production purposes or in order to improve quality. Samples are purely indicative. Packaging and weights shown may be varied in line with production requirements. Check with the sales department at the time of order.

To ensure a perfect finish, consult the recommendations for laying, cleaning and maintenance available from keope.com.

